



**Village of Hoffman Estates**  
**Building Permit Application**  
**CONDITIONS OF PERMIT ISSUANCE**

**SEWER / WATER REPAIR**

**PERMIT #:** \_\_\_\_\_

A permit for the above-referenced project is hereby approved subject to the following conditions:

|     |                                                                                                                                                                                                                 |
|-----|-----------------------------------------------------------------------------------------------------------------------------------------------------------------------------------------------------------------|
| 1.  | All work shall comply with applicable code requirements and conform to standard and accepted trade practices.                                                                                                   |
| 2.  | Pipe shall be placed on well-compacted soil per manufacturer's specifications.                                                                                                                                  |
| 3.  | A full-size clean-out is required within 5 feet of the foundation wall.                                                                                                                                         |
| 4.  | PVC Schedule 40 is required for building drain (within 5 feet of foundation wall). SDR 26 is required for building sewer (outside of 5 feet of foundation wall).                                                |
| 5.  | No shear couplings are required for all connections to existing pipe.                                                                                                                                           |
| 6.  | Water service size is a minimum 1-1/2" if replaced.                                                                                                                                                             |
| 7.  | Type K copper water service is required.                                                                                                                                                                        |
| 8.  | Round-way shall be a Mueller 1-1/2" B-25155, no substitutions.                                                                                                                                                  |
| 9.  | Trench Backfill shall follow Village Detail                                                                                                                                                                     |
| 10. | Right-of-way to be backfilled to grade with stone for paved areas (roadway, curb & gutter, sidewalk, driveway) and minimum of 6" of topsoil for unpaved areas.                                                  |
| 11. | Final restoration of right-of-way (roadway, curb & gutter, sidewalk, parkway) to be completed by Village.                                                                                                       |
| 12. | Two-way traffic to be maintained at all times. Traffic control devices shall comply with Manual for Uniform Traffic Control Devices for Streets and Highways (MUTCD).                                           |
| 13. | Lane/sidewalk closures shall comply with IDOT Highway Standards.                                                                                                                                                |
| 14. | <b>AN INSPECTION IS REQUIRED PRIOR TO COVERING PIPE AND A FINAL INSPECTION IS REQUIRED IMMEDIATELY FOLLOWING COMPLETION OF WORK. CALL CODE ENFORCEMENT AT 847-781-2631 TO SCHEDULE INSPECTION APPOINTMENTS.</b> |

The undersigned also acknowledges the following:

- The Village's Refuse Franchise Program with Groot Industries requires all permanent and temporary roll-off dumpsters must be provided by Groot. To purchase a dumpster contact 1-800-244-1977 or visit [www.groot.com](http://www.groot.com).
- There may be private covenants, conditions or restrictions on the property which control the improvements that may be made on the property. The owner is responsible to contact any Owner's Association (HOA, POA, etc.) prior to commencing work to ensure compliance with any private covenants.
- The Village, by issuance of a building permit has no power to and does not abrogate, vary, terminate, waive, or release any such covenants, conditions, and restrictions of record which may be applicable to the subject property.
- The Village of Hoffman Estates, its officials, agents and employees will not enforce private covenants nor directly supervise the performance of any work by a contractor as a consequence of the issuance of this permit.

I agree to comply with all conditions required by the Village as part of the issuance of this permit.

APPLICANT'S SIGNATURE: \_\_\_\_\_ DATE: \_\_\_\_\_  
 PRINT NAME: \_\_\_\_\_

**CONSTRUCTION HOURS:** Weekdays 7 AM to 7 PM & Weekends 8 AM to 6 PM

TRENCH BENEATH PARKWAY  
OR LANDSCAPE AREAS

TRENCH BENEATH PAVEMENT  
OR WITHIN TWO (2) FEET OF  
CURB & GUTTER OR SIDEWALK

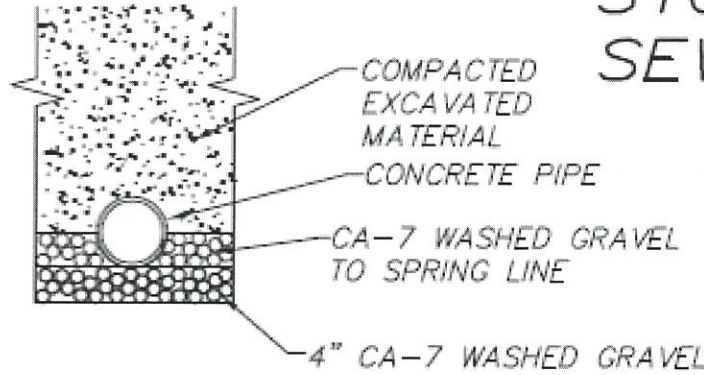

STORM  
SEWER

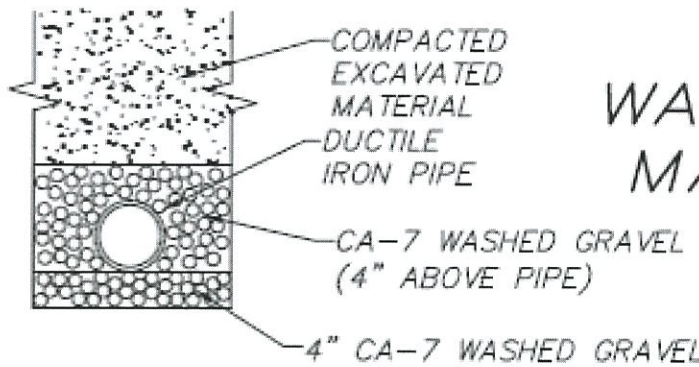
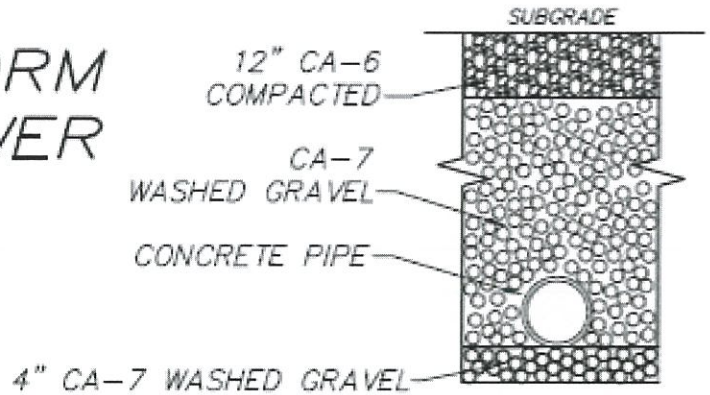

WATER  
MAIN

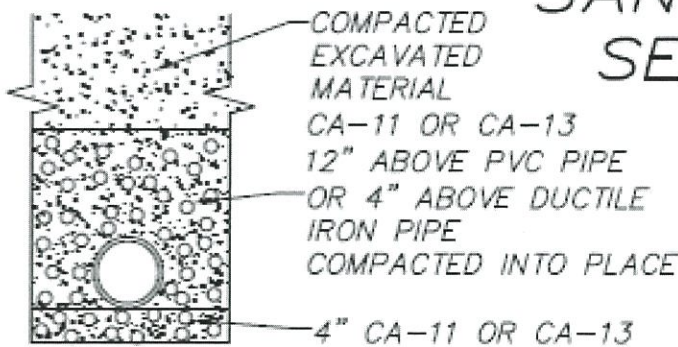
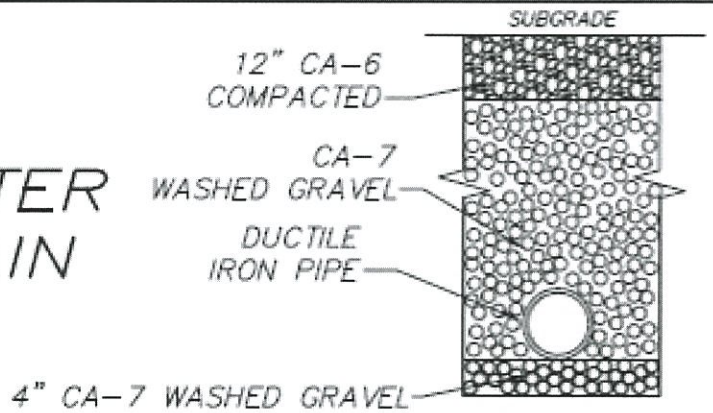

SANITARY  
SEWER

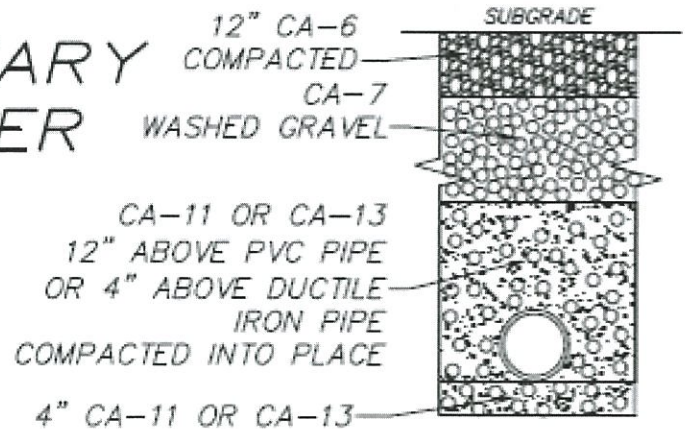

NOTE: ALL TRENCH WIDTHS SHALL EQUAL  $4/3$  PIPE DIA. + 8" OR A MINIMUM OF 32"

TRENCH BACKFILL DETAIL

| SCALE:                                                              | DATE:   | DRAFTER:                 | NO.              | REVISIONS    | BY | DATE |
|---------------------------------------------------------------------|---------|--------------------------|------------------|--------------|----|------|
| NONE                                                                | 2-16-07 | NOR                      | 1.               | MISC UPDATES | SW | 2/10 |
| VILLAGE OF HOFFMAN ESTATES<br>TRANSPORTATION & ENGINEERING DIVISION |         | FILE NAME: TYP-TREN2.DWG | SHEET NO. 1 OF 1 |              |    |      |